

Wendelhofstr. 6
 D-78120 Furtwangen/Germany
 Phone: +49 (0)7723-925-0
 Fax: +49 (0)7723-925-100
 eMail: info@IEF-Werner.de



Circuit diagram

Customer :
 Plant designation : PA-CONTROL Compact CPU4
 Project number : 1027196

Type : 2 Axes english
 Manufacturing date : 2002
 Incoming supply : 230V/50Hz/16A
 Feeding : 3x1,5mm²
 Fuse protection : 16A
 Control voltage : 24V

Created on : 16.10.02 Highest Page No. : 16
 Project leader : A.Pfeiffer
 Last changed : 28.06.05
 Editor : VOL

Editor		Date		Title page	Customer	Drawing-no. IEF	Page no.
Designer:	VOL	16.10.02				1027196	1
Modification:	VOL	28.06.05			Final customer	Drawing-no. customer	Pages
Print:		11.01.07					16
System:	Place:			PA-CONTROL Compact CPU4			

-A01.20
5.02

PA-CONTROL Compact

(X1.1)
Power supply 230V/50Hz

(X1.20/X1.21)
Power supply 24VDC/3A

(X5)
Brake

(X1.4)
24V Limit switch

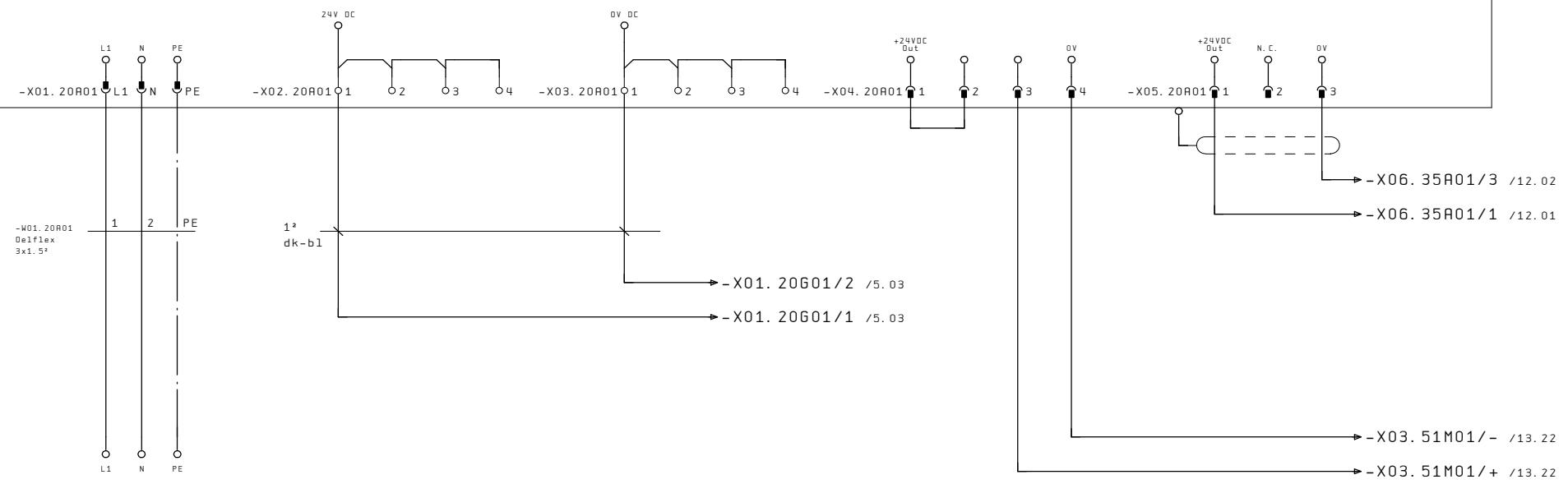

Editor		Date
Designer:	VOL	16.10.02
Modification:	VOL	28.06.05
Print:		11.01.07
System:	Place:	



PA-CONTROL Compact Power supply
PA-CONTROL Compact CPU4

Customer
Final customer

Drawing-no. IEF
1027196
Drawing-no. customer

Page no.
4
Pages
16

-R01.20
4.02

PA-CONTROL Compact

-G01.20

NT8

(X1.3)
24V IN

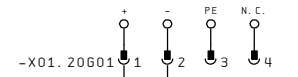

-W01.20G01
Unitronic-FD CY
3X0.5²
24V
PA-CONTROL

bn bu

4.12/ -X01.20G01/1

4.12/ -X01.20G01/2

Editor		Date	
Designer:	VOL	16.10.02	
Modification:	VOL	28.06.05	
Print:		11.01.07	
System:	Place:		WERNER

PA-CONTROL Compact CPU-Power supply

Customer

Drawing-no. IEF

Page no.

1027196

5

Final customer

Drawing-no. customer

Pages

PA-CONTROL Compact CPU4

16

-A01. 20
4. 02

PA-CONTROL Compact

-A01. 21

(X1)
COM1 Interface

CPU 4

(X2)
CAN Interface

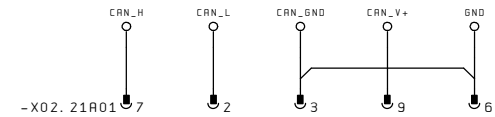
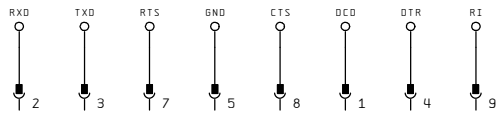
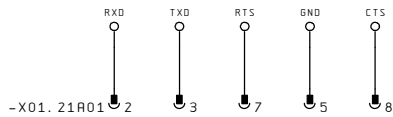

Editor		Date	
Designer:	VOL	16.10.02	
Modification:	VOL	28.06.05	
Print:		11.01.07	
System:	Place:		

PA-CONTROL Compact
Interface connection

PA-CONTROL Compact CPU4

Customer	Drawing-no. IEF	Page no.
	1027196	6
Final customer	Drawing-no. customer	Pages
		16

-A01.20
4.02

PA-CONTROL Compact

-A01.25
8.02

PAC Compact I/O-card 1

Pin 17: +24V for In-Outputs
Pin 18: +24V for In-Outputs

Pin 19: Mass 24V (GND)
Pin 36: Mass 24V (GND)
Pin 37: Mass 24V (GND)

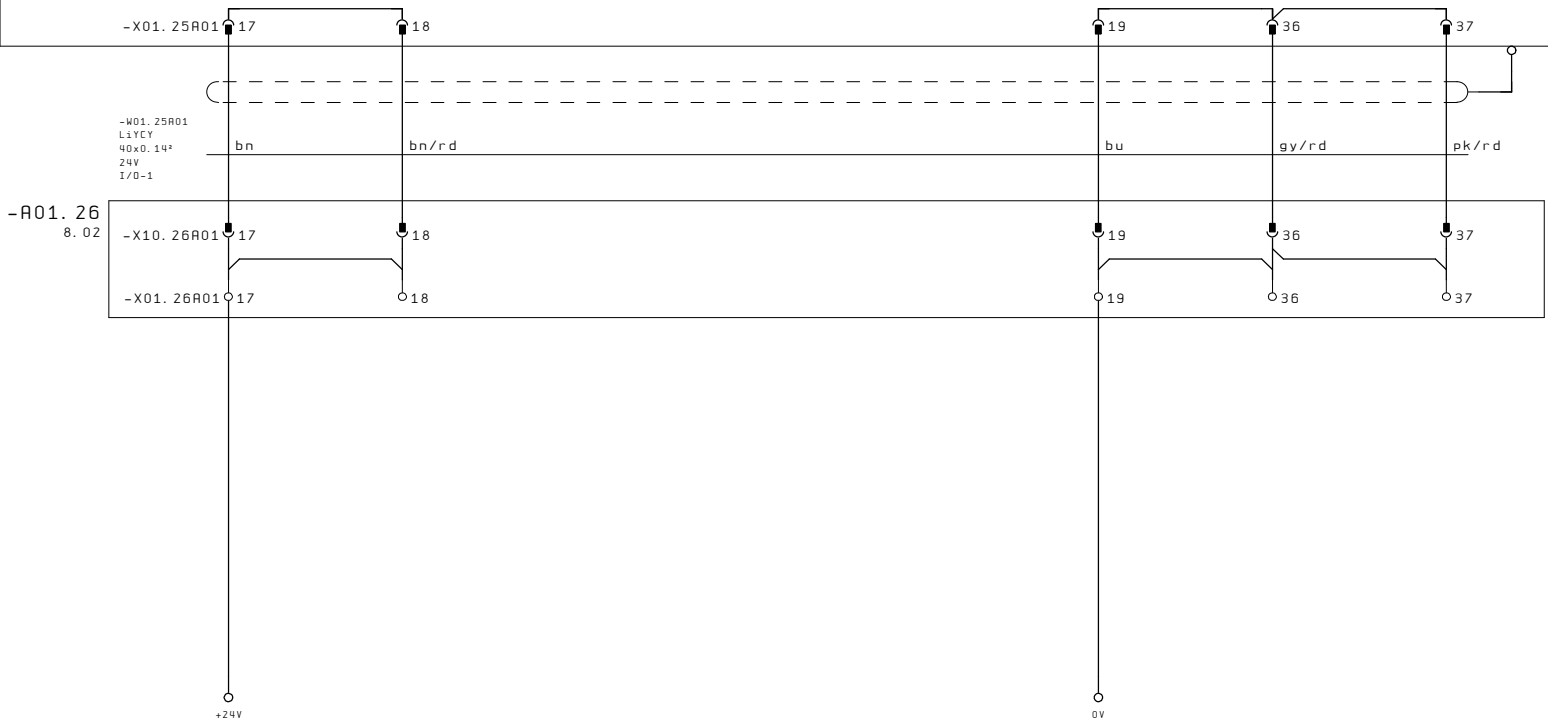

Editor		Date	
Designer:	VOL	16.10.02	
Modification:	VOL	28.06.05	
Print:		11.01.07	
System:	Place:		

Power supply PAC
Compact I/O-card

PA-CONTROL Compact CPU4

Customer	Drawing-no. IEF	Page no.
	1027196	7
Final customer	Drawing-no. customer	Pages
		16

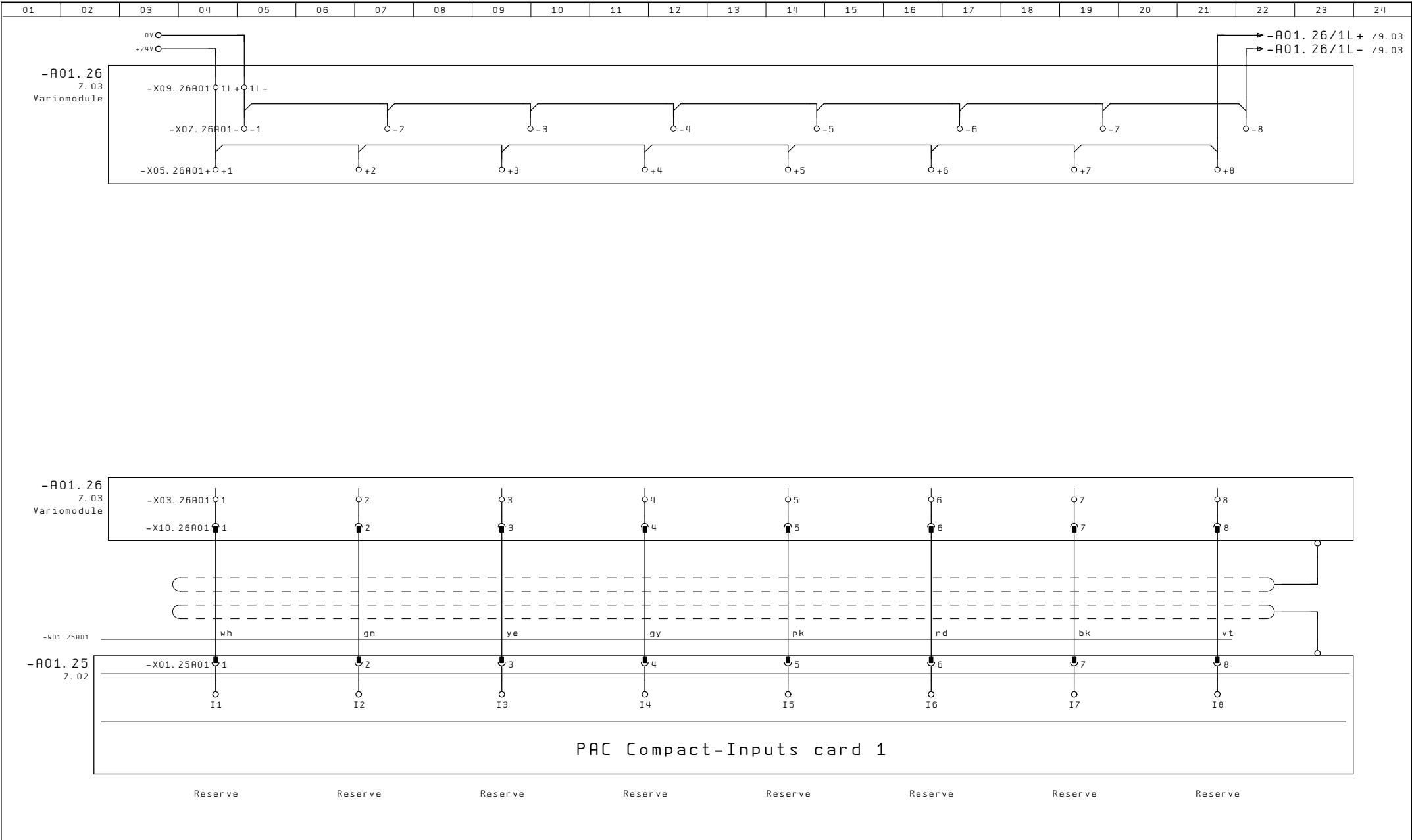

Editor		Date
Designer:	VOL	16.10.02
Modification:	VOL	28.06.05
Print:		11.01.07
System:	Place:	



PAC Compact Inputs I1-I8	
PA-CONTROL Compact CPU4	

Customer	Drawing-no. IEF	Page no.
	1027196	8
Final customer	Drawing-no. customer	Pages
		16

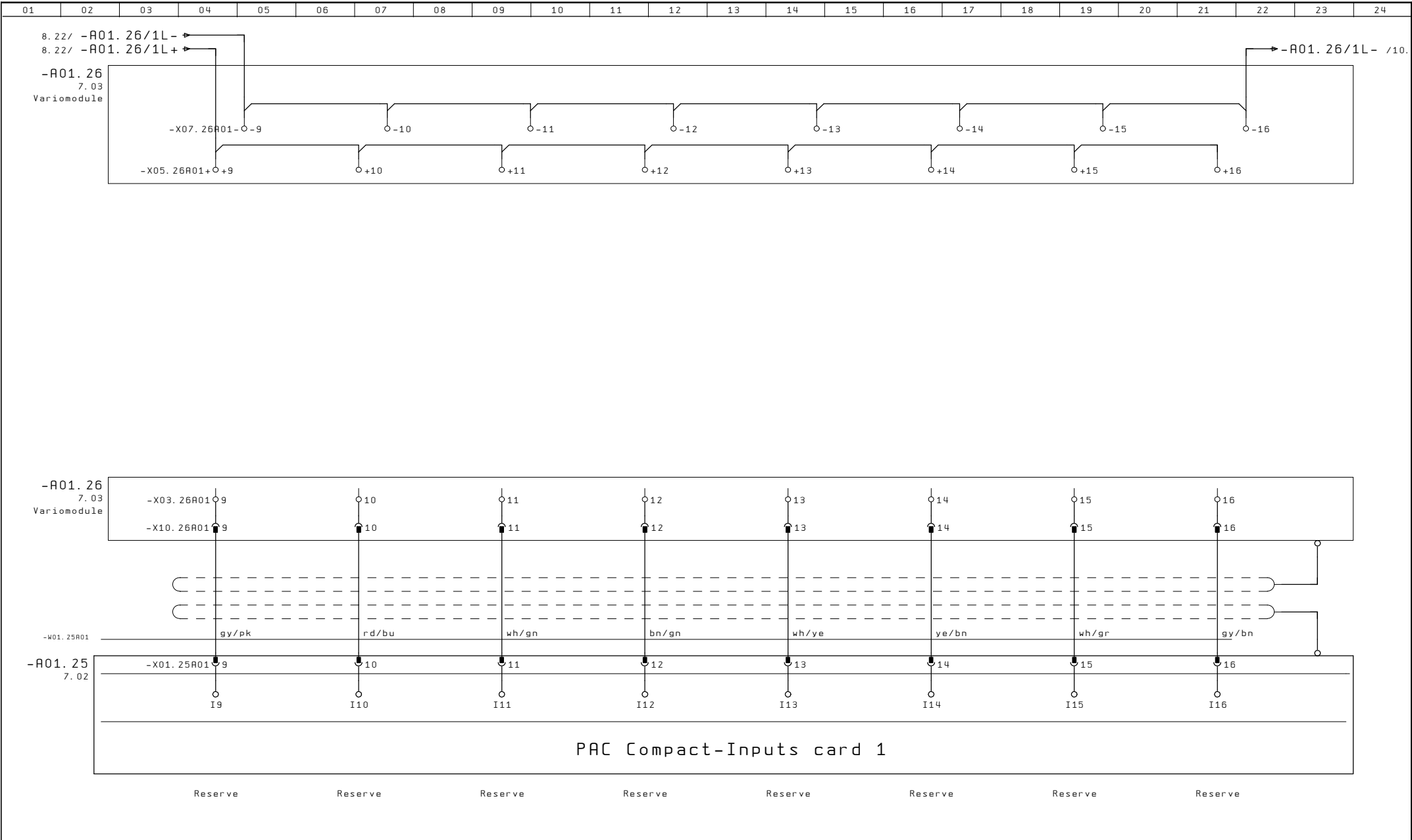

Editor		Date
Designer:	VOL	16.10.02
Modification:	VOL	28.06.05
Print:		11.01.07
System:	Place:	



PAC Compact Inputs I9-I16	
PA-CONTROL Compact CPU4	

Customer	Drawing-no. IEF	Page no.
	1027196	9
Final customer	Drawing-no. customer	Pages
		16

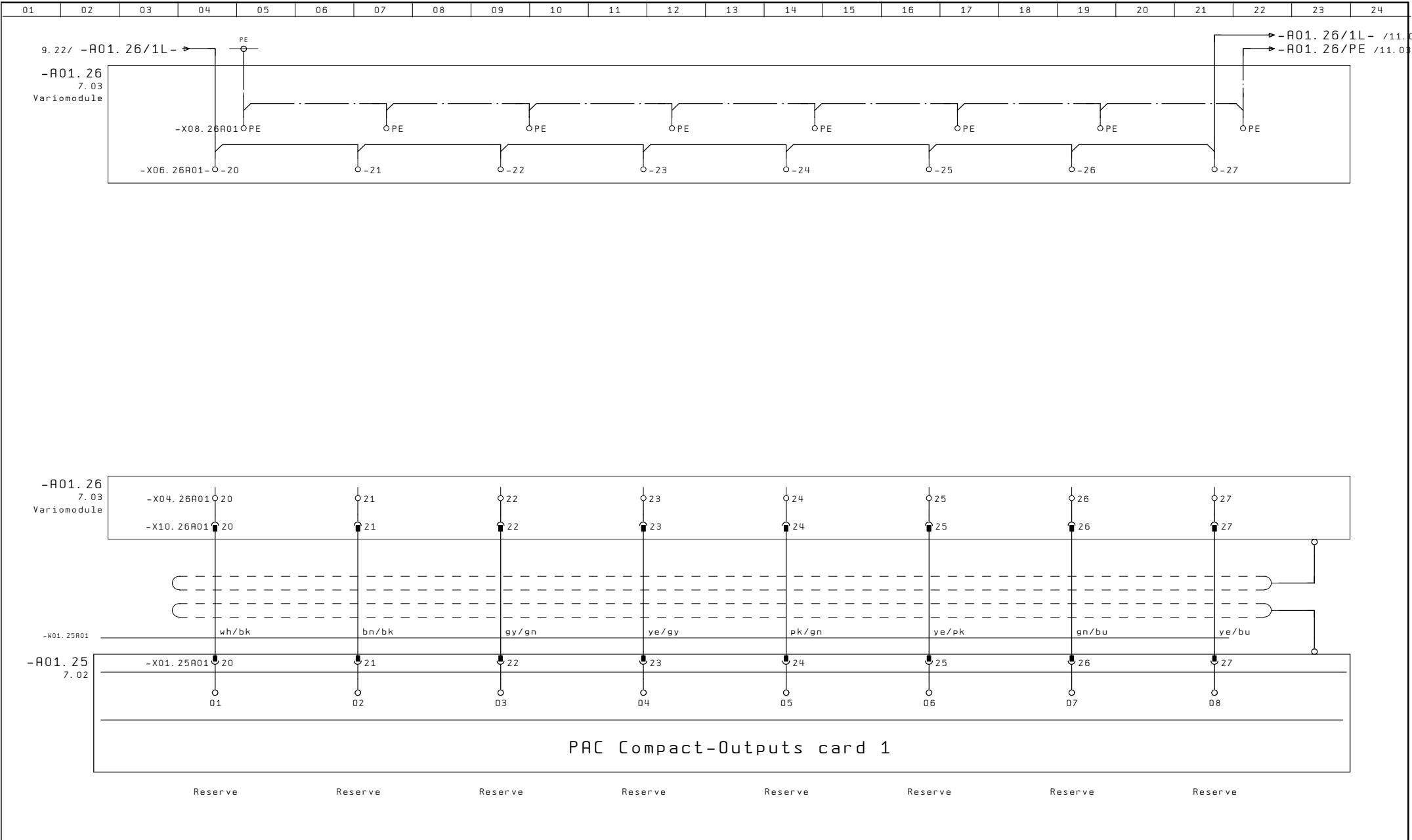

Editor		Date
Designer:	VOL	16.10.02
Modification:	VOL	28.06.05
Print:		11.01.07
System:	Place:	



PAC Compact Outputs
01-08

PA-CONTROL Compact CPU4

Customer	Drawing-no. IEF	Page no.
	1027196	10
Final customer	Drawing-no. customer	Pages
		16

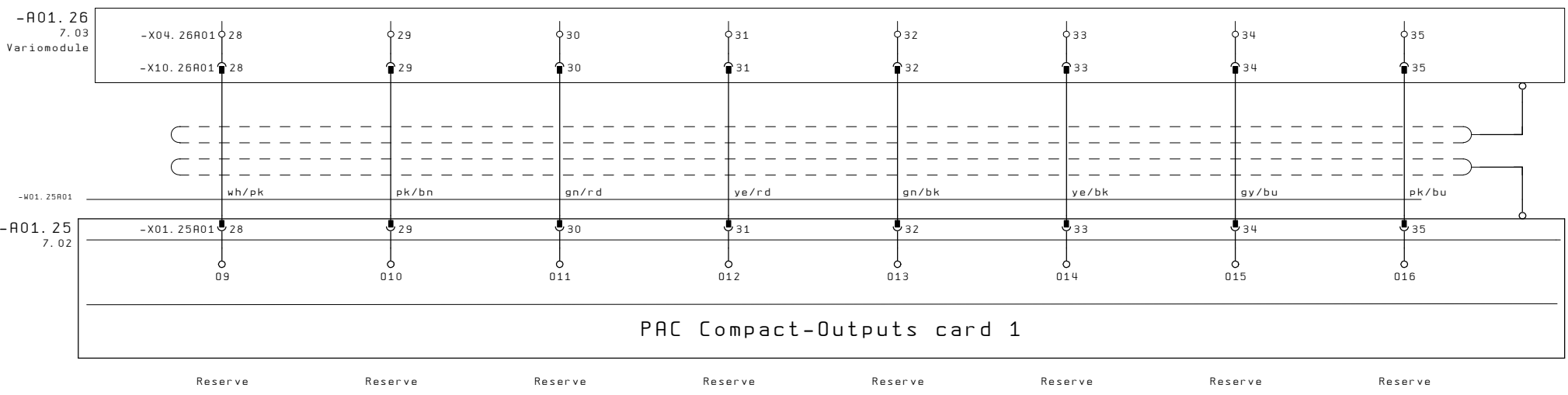
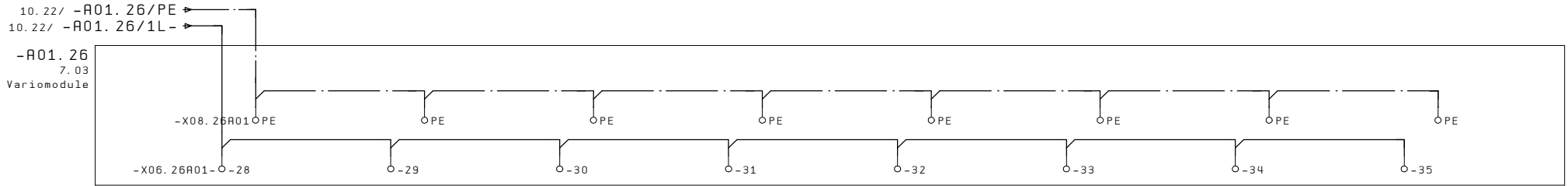

PAC Compact-Outputs card 1

Editor		Date	
Designer:	VOL	16.10.02	
Modification:	VOL	28.06.05	
Print:		11.01.07	
System:	Place:		



PAC Compact Outputs	
09-016	
PA-CONTROL Compact CPU4	

Customer	Drawing-no. IEF	Page no.
	1027196	11
Final customer	Drawing-no. customer	Pages
		16

-A01.20
4.02

PA-CONTROL Compact

-A01.41

Power card 1

(X2) Motor

(X4) ENC

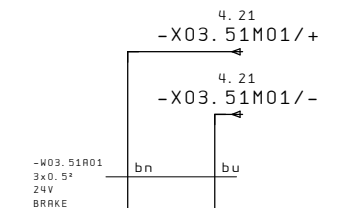
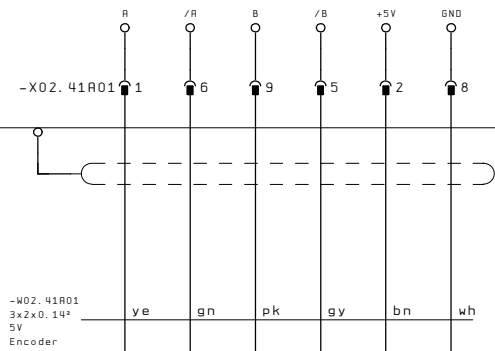
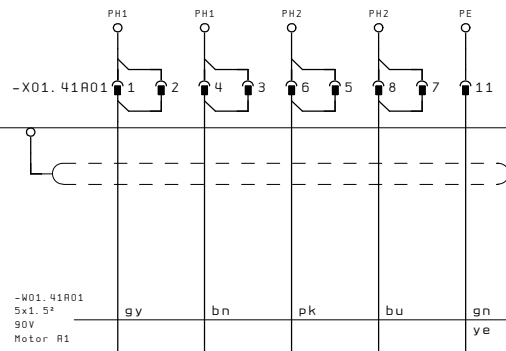

-M01.51

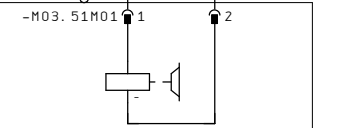
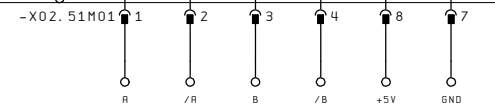
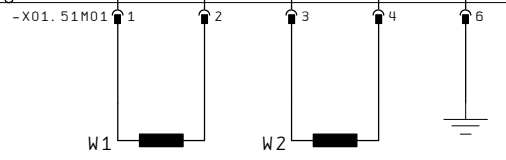

Motor

Rotation monitoring

Brake

optional

Editor		Date	
Designer:	VOL	16.10.02	
Modification:	VOL	28.06.05	
Print:		11.01.07	
System:	Place:		



Power card 1
A1-axis 2
phase stepper motor
PA-CONTROL Compact CPU4

Customer	Drawing-no. IEF	Page no.
	1027196	13
Final customer	Drawing-no. customer	Pages
		16

-A01. 20
4. 02

PA-CONTROL Compact

-A02. 41

Power card 2

(X2) Motor

(X4) ENC

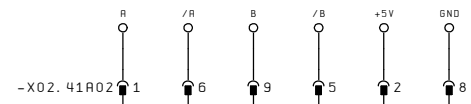
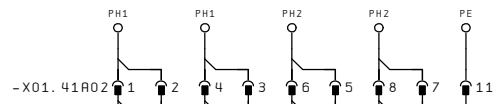

-W01. 41A02
5x1.5²
90V
Motor A2

gy bn pk bu gn ye

-W02. 41A02
3x2x0.14²
5V
Encoder

ye gn pk gy bn wh

-W03. 51A02
3x0.5²
24V
Brake

bn bu Connection for brake

-M02. 51

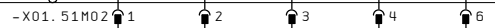

W1 W2

Motor

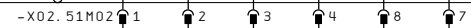

R /R B /B +5V GND

Rotation monitoring

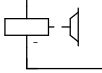
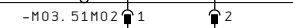

Brake

optional

Editor		Date	
Designer:	VOL	16.10.02	
Modification:	VOL	28.06.05	
Print:		11.01.07	
System:	Place:		

Power card 2
A2-axis 2
phase stepper motor
PA-CONTROL Compact CPU4

Customer	Drawing-no. IEF	Page no.
	1027196	14
Final customer	Drawing-no. customer	Pages
		16

-A01. 20
4. 02

PA-CONTROL Compact

-A01. 41

Power card 1

(X2) Motor

(X4) ENC

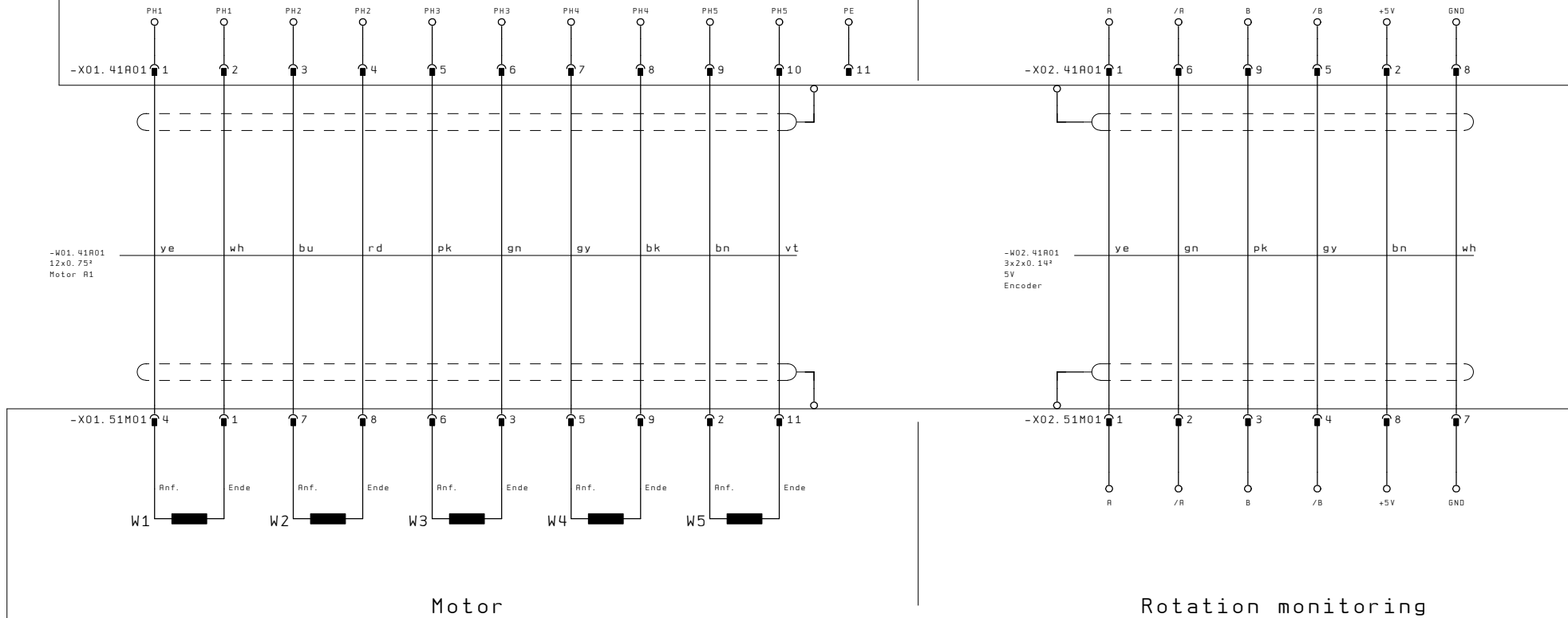

-M01. 51

Editor		Date	
Designer:	VOL	16.10.02	
Modification:	VOL	28.06.05	
Print:		11.01.07	
System:	Place:		



Power card 1
A1-axis 5-phase
stepper motor
PA-CONTROL Compact CPU4

Customer	Drawing-no. IEF	Page no.
	1027196	15
Final customer	Drawing-no. customer	Pages
		16

-A01. 20
4. 02

PA-CONTROL Compact

-A02. 41

Power card 1

(X2) Motor

(X4) ENC

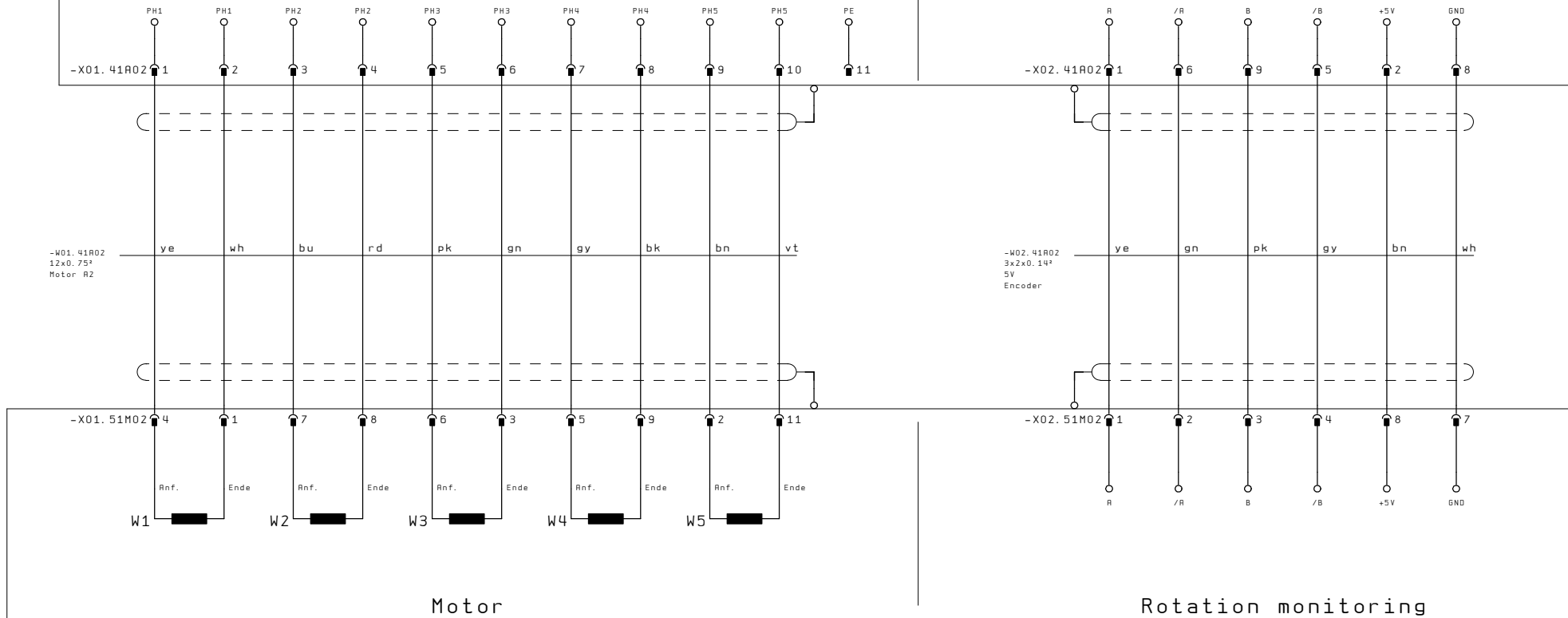

-M02. 51

Editor		Date	
Designer:	VOL	16.10.02	
Modification:	VOL	28.06.05	
Print:		11.01.07	
System:	Place:		



Power card 2
A2-axis 5-phase
stepper motor
PA-CONTROL Compact CPU4

Customer	
Final customer	

Drawing-no. IEF	1027196
Drawing-no. customer	

Page no.	16
Pages	16