

Wheel Gauging System R2010

Wheel Gauging Machine R2010

Car and Commercial Vehicles

The patented wheel gauging machine **R2010** was developed for measuring geometrical characteristics of motor vehicle wheels. It combines the functions measuring data collection, measuring process as well as calculation and displaying the measured characteristics in one system. The wheel gauging machine **R2010** for 100% inspection is a fully automatic system for the integration in production lines. Mechanics, electrics and software are designed modularly and will be configured individually according to customer's specifications. The single components are optimally configured for the customer by integration of latest technical expertises in the fields of IT- technology, optics, laser and drive engineering. By using IEF linear modules with innovative drive technology, shortest cycle times with highest precision and repeat accuracy are achieved. Calibration of the gauging system is carried out by using a calibration master.

The wheel gauging machine **R2010**

- For 100% control integrated in a fully automatic system in your production line
- In the assembly of a SPC system (statistical process control) for laboratory measurements, especially for wheels, rims and discs

Patent, Calibration

Patented system for the measurement of geometrical characteristics on passenger car wheels, commercial car wheels and earthmoving equipment wheels. Calibration of the system with only ONE calibration master.

Interfaces

- Communication with logistics control
- Measurement data to customer system

Typical Measurement Features

Standard

- Radial/axial runouts inboard/outboard
- 1. - 10. harmonic analysis (Fourier-Analyse) of radial/axial runouts
- Rim width
- Offset
- Bead seat circumference inboard/outboard

Options

- Center hole diameter
- Hump circumference inboard/outboard
- Material thickness in the inner rim well
- Bolt hole positions, pitch circle diameter and height
- Flatness of the contact surface

Further options on request

History

IEF made Wheel Gauging Systems

1984: First contact between Lemmerz and IEF Werner to develop, as partners, a wheel gauging system

1987: First generation: various wheel gauging systems (worldwide still in production until today)

1992: Second generation: base frame made of polymer concrete

2004: Third generation: new design of the wheel gauging system regarding new technologies --> **R2010**

2005: Until today: continuous further development regarding latest technologies and customer requests

2008: First 3rd generation wheel gauging system delivered to Hayes Lemmerz, Hoboken, Belgium

2011: Fourth generation: new design of the clamping unit of the wheel gauging system
Clamping system – flexible: 52mm – 88mm without changeable parts
Clamping system – collets: 50mm – 161mm new design of collets vulcanized with rubber

2011: First system of 4th generation delivered to NISSAN, China

2012-2022: 4th generation systems are in use worldwide to guarantee the quality of wheels in premium cars, like BMW, DAIMLER, PORSCHE, RENAULT, JLR, NISSAN, PSA, HONDA, VOLVO, VW, FORD, GM, FIAT, ...

Wheel manufacturers:

Maxion Wheels, Accuride Wheels, Magnetto Wheels, Jingu Wheels, BBS, Cromodora, Brock

TRW assemblies:

Hofmann, Schenck Rotec, Eurofit, Truck & Wheels, Reifen Gundlach, Schedl, Leadec, Erlos, Fengshen

International Standards

EUWA (Association of European Wheel Manufacturers)

The EUWA requires their members to fulfill the requirements by the automobile industry, to receive the requirements of the quality standards of ISO9001.

E.T.R.T.O. (European Tyre and Rim Technical Organisation)

The activities of the E.T.R.T.O. are confined to technical aspects of tyres and rims (wheels) as far as fitting and use are concerned.



Geometrical Characteristics at the Bead Seat Area

For historical reasons, some geometrical characteristics (dimensions) are not physically present (for example: the bead seat/rim flange edge). This makes it difficult to record these dimensions with repeat accuracy while using standard gauging equipment.

Physically recordable: mandrel diameter, bead seat inclination and rim width
Physically not recordable only calculation: specified diameter and flange height

In the recent years, the stated tolerance ranges have become increasingly small due to the demands of the automobile industry.

Why measure tactile with a ball \varnothing "16 mm"

During the revolution of the wheel, the ball follows directly the shape of the bead seat. It is the true measurement of the radial and axial runouts on the bead seat area. The radial runout depends on the shape of the axial runout and the axial runout depends on the shape of the radial runout.

Using an optical sensor, the point is always adjusted in one height for the radial runout and in one diameter for the axial runout

The environment of the installation of the Wheel Gauging System is not in a laboratory, but in a rough industrial fabrication area. Dust of rubber, residues of soap and other industrial trash are big influences on the measurements by an optical system, using a tactile system these influences are minor. Another important point for the tactile measurement are the different paintings of the wheels.

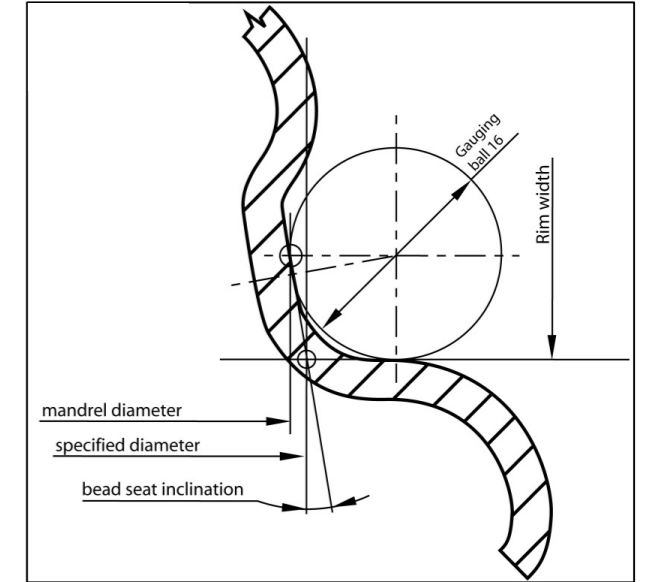

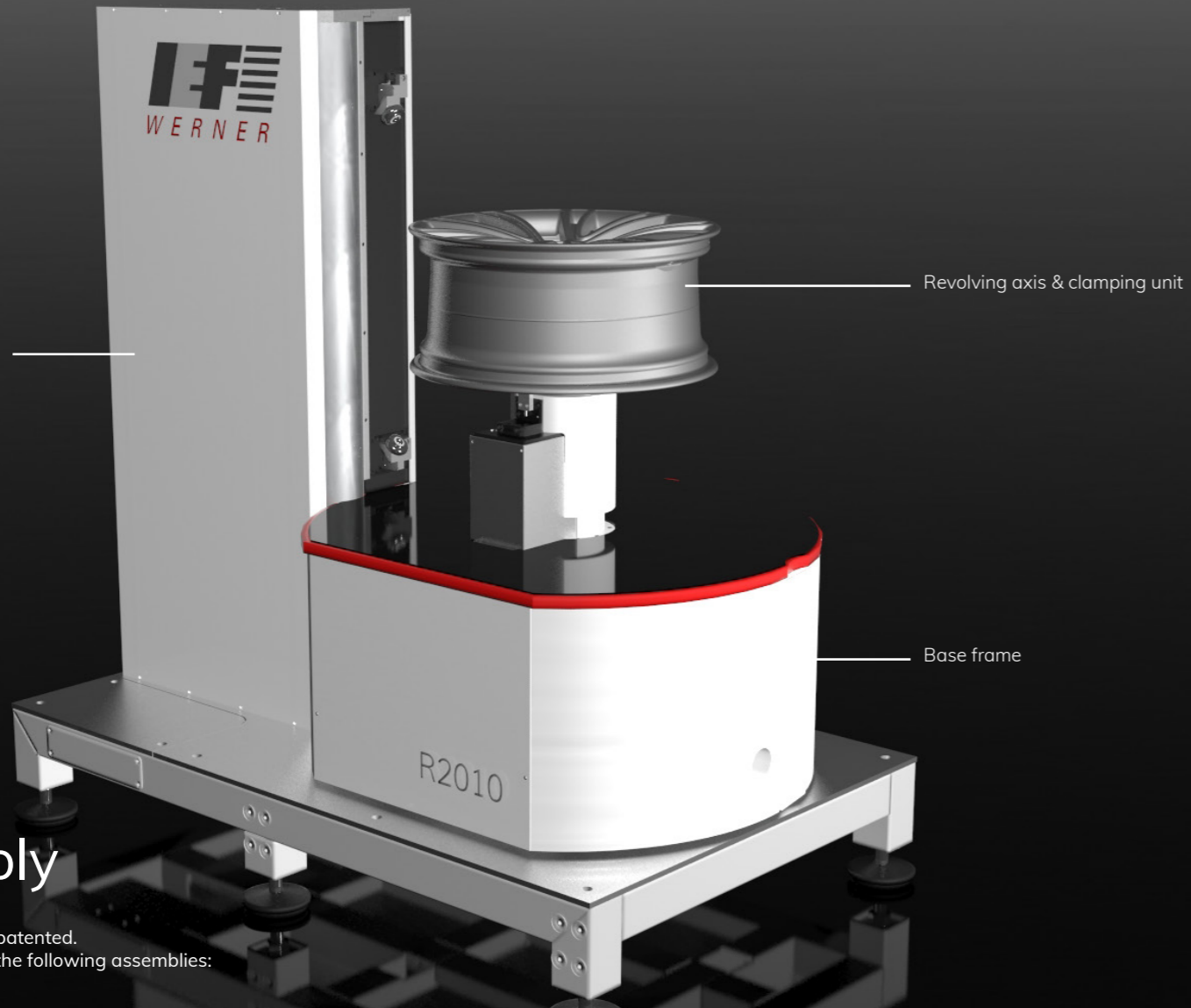

Measuring tower & measuring heads

Revolving axis & clamping unit

Base frame

Base assembly

The Wheel Gauging System R2010 is patented.
It is build up, in the base version, with the following assemblies:

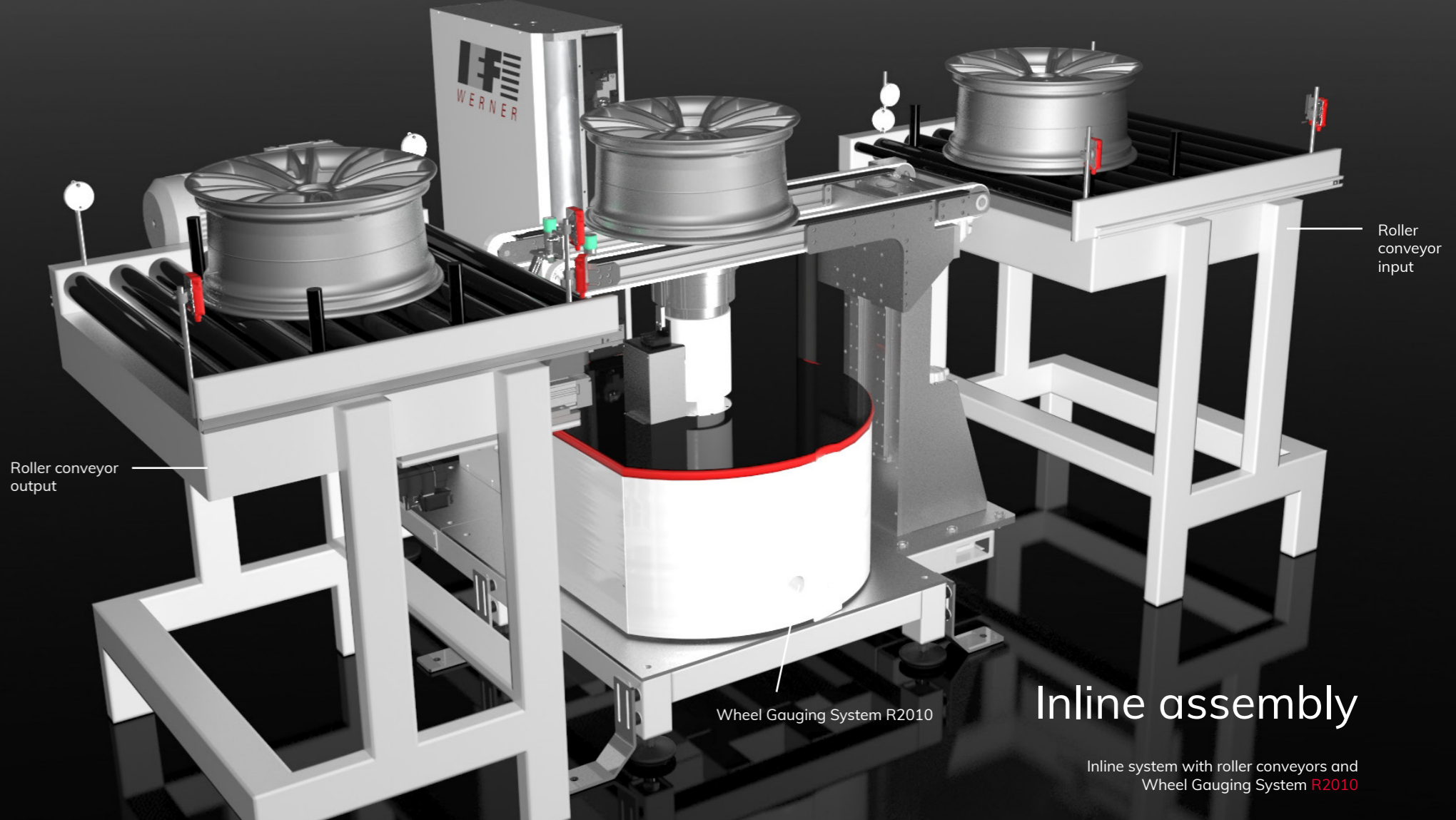

Roller conveyor output

Roller conveyor input

Wheel Gauging System R2010

Inline assembly

Inline system with roller conveyors and
Wheel Gauging System R2010

100%-Inline-Wheel Gauging System R2010

Wheel Gauging System for the production site

Our customers

- Wheel manufacturer (Maxion, Accuride, Magnetto, BBS, Brock, Jingu,)
- Service provider (Eurofit, Truck & Wheels, Reifen Gundlach, Schedl, Fengshen,)
- Machine manufacturer (Hofmann, Schenck, Seeb,)



Laboratory-Wheel Gauging System R2010

Wheel Gauging System for the laboratory site

Our customers

- Wheel manufacturer (Maxion, Accuride, Magnetto, Baosteel, Jingu, Cromodora,)
- Automobile manufacturer (Daimler, Nissan,)



Overview of the main assemblies of an inline system

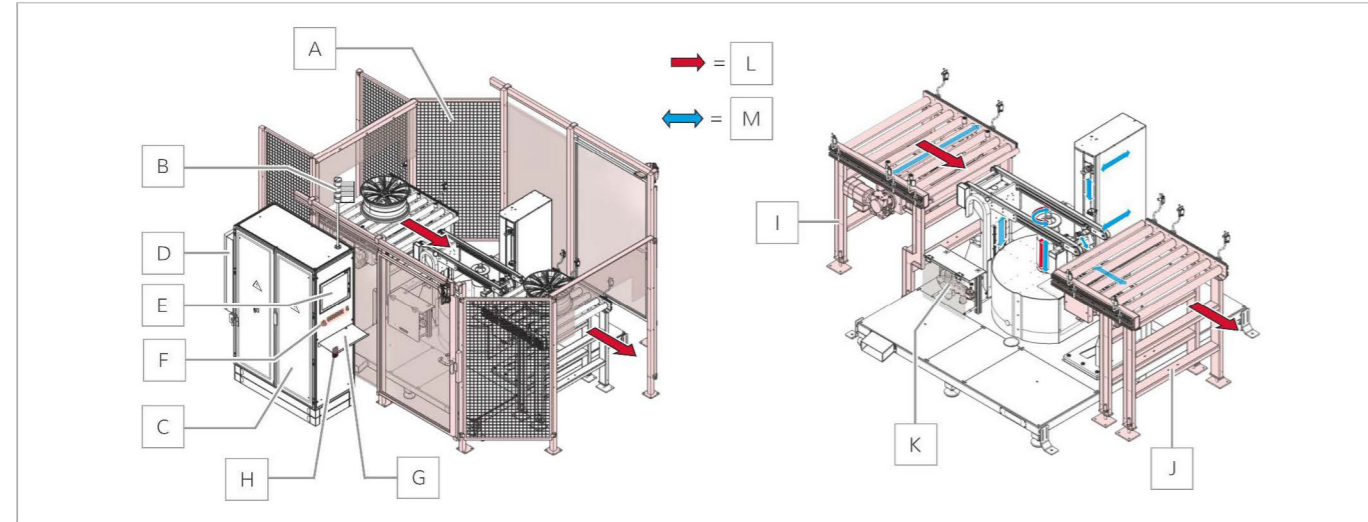
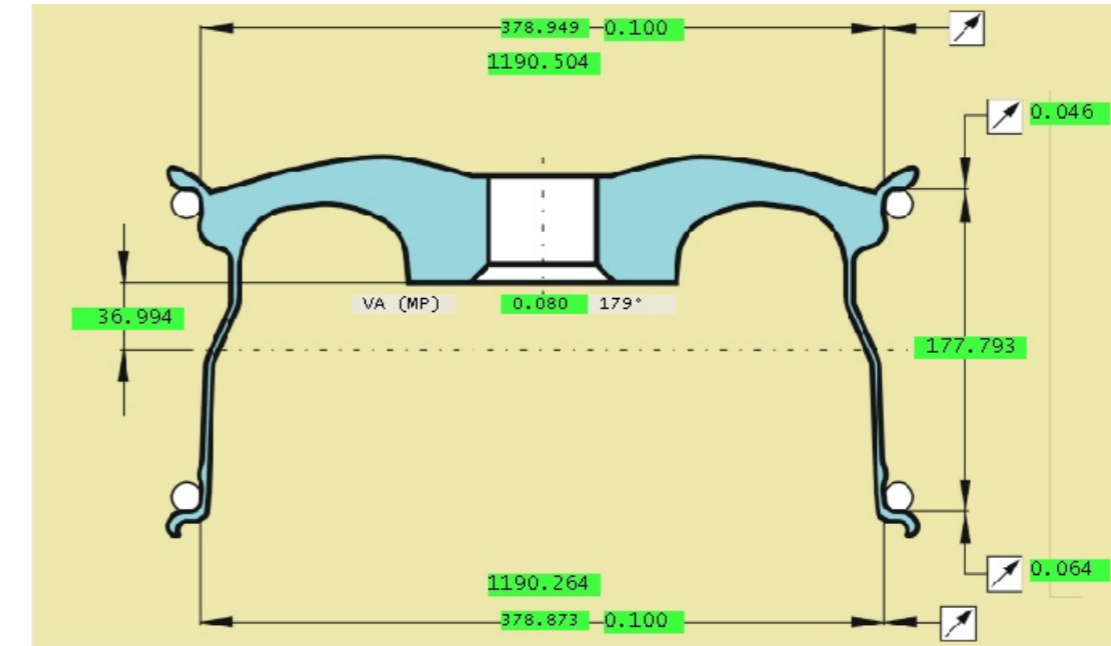

Figure 1 Overview of the main assemblies of the system (system overview)

A Safety fence system	B Pilot lamps	C Control cabinet cpl. (Incl. cooling unit, operator console (monitor), keyboard support, keyboard, mouse and switches and buttons for operating the equipment)
D Cooling unit	E Monitor	F Switches and buttons on the operator console
G Keyboard / mouse support	H Service socket	I Roller conveyor input side with transducer in the substructure
J Roller conveyor output side	K Maintenance unit	L Running direction of the wheels →
M Axes/cylinder movements (electrically or pneumatically) ↔		

Display of the measured values in the wheel graph after each measurement



Display of the measured values in a table after each measurement

No.	Charact.	Nom.Val	LT	UT	Value	Dev.	Phase	UT	MT	OT	U
1	RR Out	0.000	*	0.300	0.100		*				U
2	RR O&I	0.000	*	0.300	0.094		*				U
3	RR In	0.000	*	0.300	0.100		*				U
5	AR O	0.000	*	0.300	0.046		*				U
6	AL O&I	0.000	*	0.800	0.049		*				U
7	AR I	0.000	*	0.300	0.064		*				U
8	Dia O	378.870	-0.300	0.400	378.949		*				U
9	Dia I	378.870	-0.300	0.400	378.873		*				U
21	Circ O	1190.300	-0.900	1.200	1190.504		*				U
22	Circ I	1190.300	-0.900	1.200	1190.264		*				U
23	RW	177.800	-0.500	0.500	177.793		*				U
26	Offset	37.000	-0.500	0.500	36.994		*				U
129	1h RR O	0.000	*	0.300	0.087		174				U
130	2h RR O	0.000	*	0.500	0.007		25				U
140	1h RR I	0.000	*	0.300	0.074		186				U
141	2h RR I	0.000	*	0.500	0.049		18				U
151	1h AR O	0.000	*	0.300	0.022		6				U
162	1h AR I	0.000	*	0.300	0.055		10				U
173	VA (MP)	0.000	*	0.300	0.080		179				U
998	ValveAng	0.000	0.000	360.000	77.000		*				U

Example 1:

No.: 8

Characteristic: Dia O = rim diameter outside

Nominal value = 378.870mm

LT (lower tolerance) = -0.300

UT (upper tolerance) = 0.400mm

Value (measured value) = 378.949mm

Example 2:

No.: 173

Characteristic: VA (MP) = match point

(1. Harmonic of runout outside and inside)

U = unilateral = LT not specified

Nominal value = 0.000mm

LT (lower tolerance) = * (not specified)

UT (upper tolerance) = 0.300mm

Value (measured value) = 0.080mm

Phase (angle match point) = 179°

Explanation of match point calculation

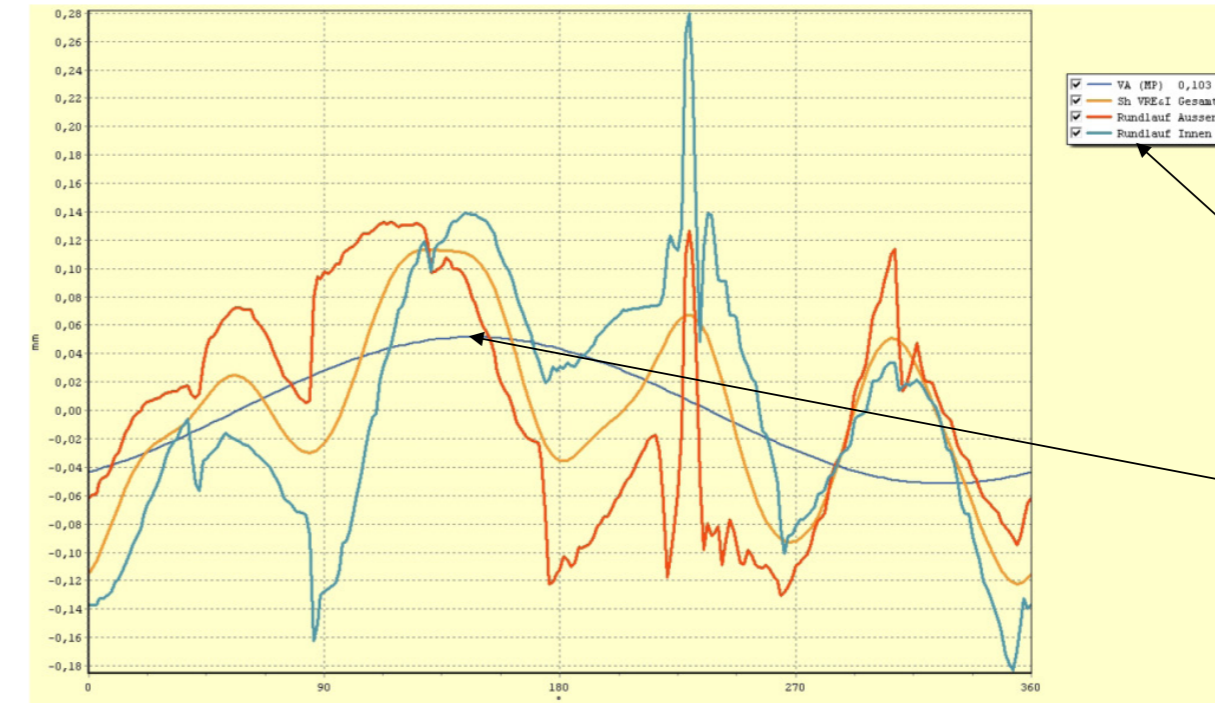

Display of the original readings as a graph

Display of the calculation of the match point as a graph (here high-point)

Specifications

Wheel dimensions

Wheel diameter	14" to 24"
Rim width	4J to 14J
Offset	-20mm to 80mm (standard)
Center hole diameter	52 to 88 (flexible clamping) 52 mm up to 161 mm (clamping rings - chucks)
Wheel weight	up to 30 Kg

Characteristics

- Radial - and lateral runouts (individual and average)
- 1 - 10 harmonics of radial- and lateral runouts (individual and average)
- Rim width
- Offset
- Bead seat diameter / -circumference

Options

- Center hole diameter
- Bolt hole positions and PCD

Innovations from the Black Forest

Our service technicians ensure quick and competent support, in all product ranges and around the clock. Furthermore IEF-Werner offers product-, application- and customer-specific in-house trainings. Of course, if desired as well at the customer's site.

- Commissionings
- Retrofitting, modifications and updates
- Repairs and spare parts
- Individual maintenance agreements
- Fault analysis and production optimisation
- Trainings

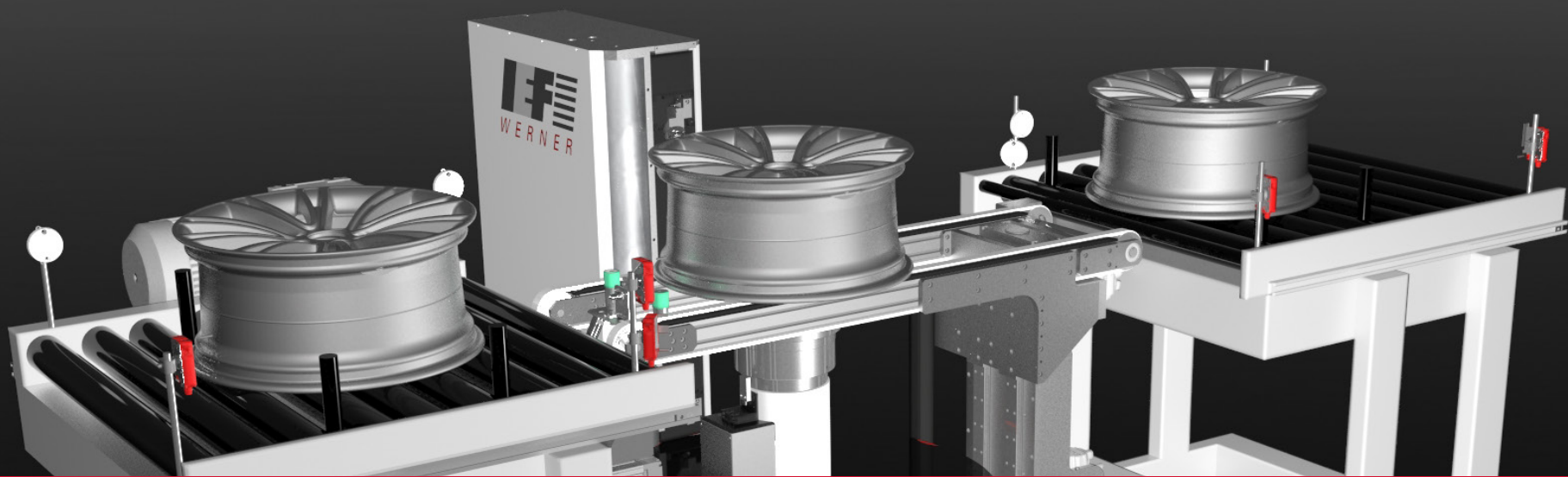

11.04.22 | DEEN 1443615 / V1

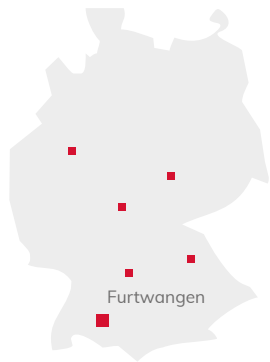

Your contact:

Giuseppe Morreale
Product Management

☎ +49 7723/925-208

📞 +49 160/901 222 68

✉ giuseppe.morreale@ief-werner.de

IEF-Werner GmbH | Wendelhofstr. 6 | 78120 Furtwangen | Telefon +49 7723/925-0 | info@ief-werner.de | www.ief.de

IEF  [®]
WERNER